

พอลอต punches ชนิดไม่ยึดตายตัว ผิวขัดมัน
(PILOT PUNCHES -MOVABLE LAPPED TYPE-)

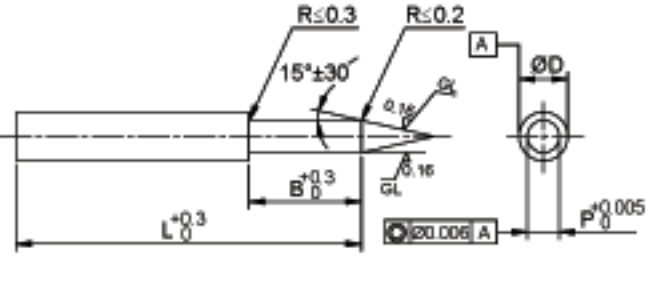

ชนิด (Type)	ลำตัวพunch Shank dia. ØD	STEEL GRADE M HARDNESS H	Catalog No.	Views
- Lapped type - ปลายแหลม ผิวขัดมัน 	Dg6	SKD11 60~63HRC	L-PPM	
		HAP40 64~67HRC	L-PPPM	
	D -0.005 -0.010	SKD11 60~63HRC	AL-PPM	
		HAP40 64~67HRC	AL-PPPM	

Catalog No. ชนิด (Type)	ØD	L	min. P max. 0.01mm.	B 0.1mm.
SKD11 L-PPM L-PPPM	3	42 52 62 72	1.00~2.50	2.0 ~ 23.0 (B ≤ L/2)
	4	42 52 62 72	1.50~3.50	
HAP40 AL-PPM AL-PPPM	5	42 52 62 72	2.00~4.50	
	6	42 52 62 72	2.50~5.50	
	8	42 52 62 72 82	3.00~7.50	

 **Order** **Catalog No.** **ØD** - **L** - **P** - **B**

L-PPM 8 - 72 - P5.88 - B20.0

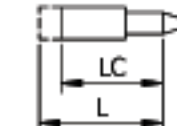
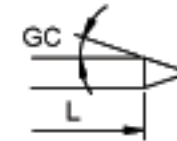
ค่าบริการเพิ่มเติมในการเปลี่ยนค่าต่าง ๆ จากมาตรฐานที่กำหนด (Charges for alterations)

ลักษณะการเปลี่ยนแปลง (Alterations)	Code การตั้ง	Spec.	ค่าบริการ/ชิ้น(บาท) (Baht/Piece)
	PC	PC ≥ $\frac{P_{min.}}{2}$ 0.01mm. ถ้า PC = 0.5-0.99 ⇒ Bmax. = 8	40
	LC	B + 9 < LC < L 0.1mm.	40
	GC	15° < GC ≤ 45° 1°	80
	BKC	B + 0.3 ⇒ +0.05 0 0	80

■ SKD11 **B** ราคา บาท/ชิ้น (Baht/Piece)

ØD	L-PPM	AL-PPM
3	754	809
4	704	759
5	710	765
6	721	776
8	787	842

■ HAP40 **B** ราคา บาท/ชิ้น (Baht/Piece)

ØD	L-PPPM	AL-PPPM
3	1,062	1,128
4	979	1,045
5	990	1,056
6	1,007	1,073
8	1,122	1,188